

UC54-22 Universal Motor

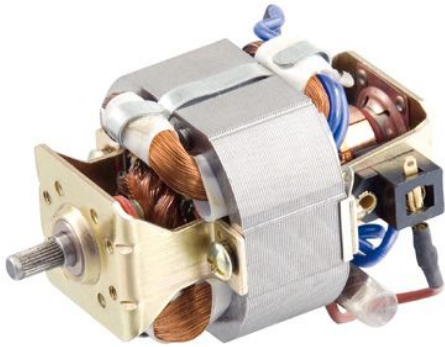

- Application—
- Coffee mill
- Blender
- Juicer
- Soybean milk machine
- Hairdryer
- Food Processor and so on.

Mechanical Dimensions

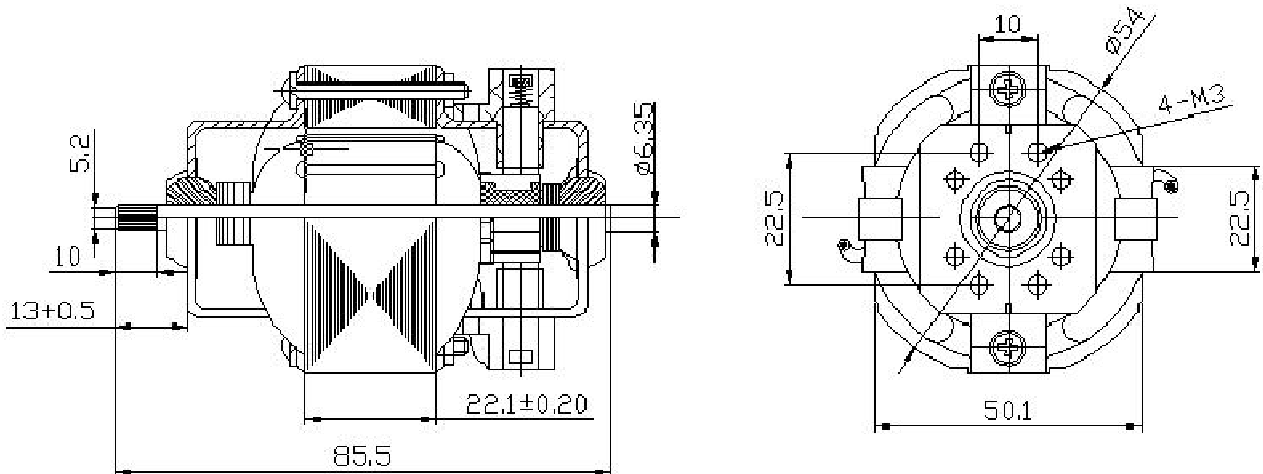

Technical Data

Model	Voltage (V)	Frequency (Hz)	No-Load			On-Load			Input power (W)	Output power (W)	Eff (%)
			Speed (RPM)	Current (A)	Power (W)	Speed (RPM)	Torque (N.m)	Current (A)			
UC54-22	220	50/60	23000	0.65	65	10000	0.07	1.75	180	92	51.2
UC54-22	110	50/60	23000	0.30	65	10000	0.07	0.85	180	92	51.2

Remark: We can produce according to customers requirement.

UC54-25 Universal Motor

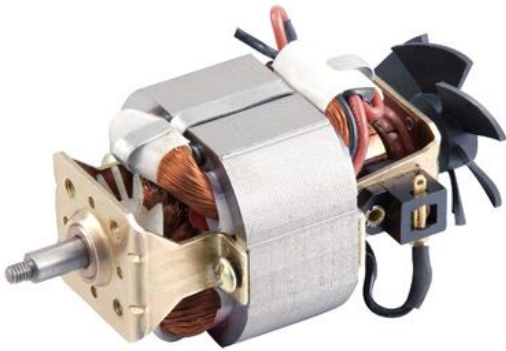

- Application—
- Juicer
- Blender
- Egg Beater
- Coffee mill
- Hairdryer
- Food Processor and so on.

Mechanical Dimensions

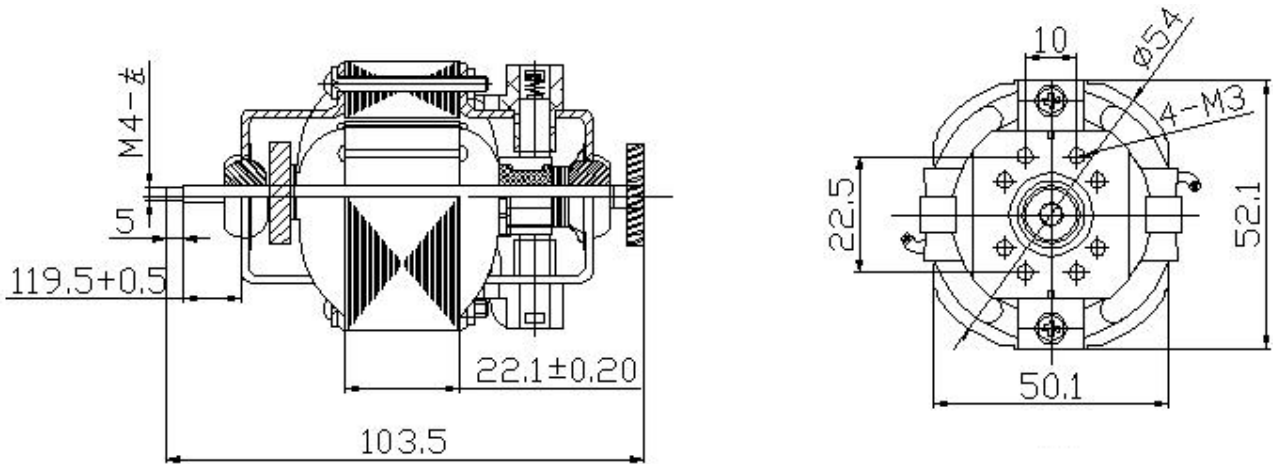

Technical Data

Model	Voltage (V)	Frequency (Hz)	No-Load			On-Load			Input power (W)	Output power (W)	Eff (%)
			Speed (RPM)	Current (A)	Power (W)	Speed (RPM)	Torque (N.m)	Current (A)			
UC54-25	220	50/60	23000	0.354	75						

Remark: We can produce according to customers requirement.

UC54-40 Universal Motor

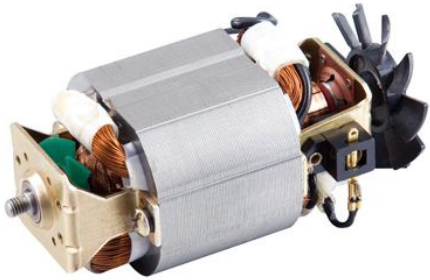

- Application—
- Juicer
- Milk Shaker
- Blender
- Meat grinder
- Food Processor
- Egg Beater and so on.

Mechanical Dimensions

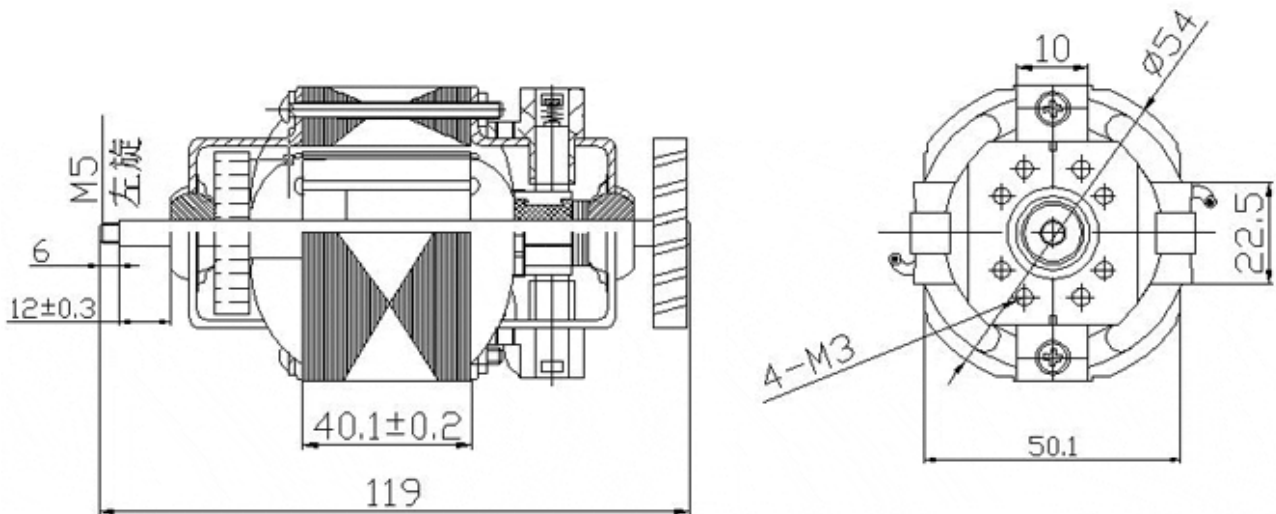

Technical Data

Model	Voltage (V)	Frequency (Hz)	No-Load			On-Load			Input power (W)	Output power (W)	Eff (%)
			Speed (RPM)	Current (A)	Power (W)	Speed (RPM)	Torque (N.m)	Current (A)			
UC54-40	220	50/60	23500	0.42	90	10600	0.115	1.08	247.6	127.5	51.2

Remark: We can produce according to customers requirement.

UC68-22 Universal Motor

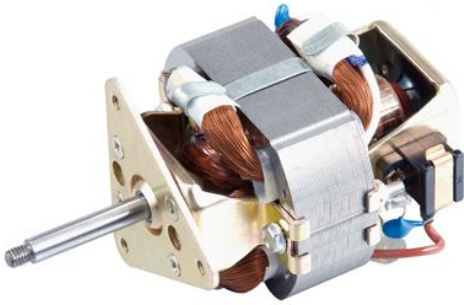

- Application—
- Juicer
- Milk Shaker
- Meat grinder
- Food Processor
- Blender
- Egg Beater and so on.

Mechanical Dimensions

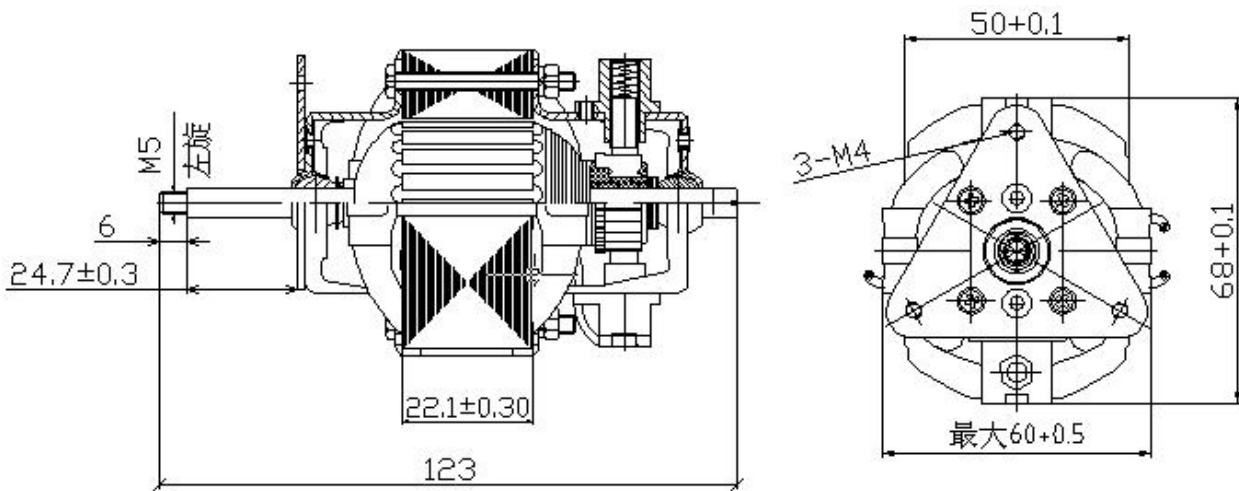

Technical Data

Model	Voltage (V)	Frequency (Hz)	No-Load			On-Load			Input power (W)	Output power (W)	Eff (%)
			Speed (RPM)	Current (A)	Power (W)	Speed (RPM)	Torque (N.m)	Current (A)			
UC68-22	220	50/60	19800	0.34	74	6680	0.145	1.035	219.3	100.5	45.8

Remark: We can produce according to customers requirement.

UC68-26 Universal Motor

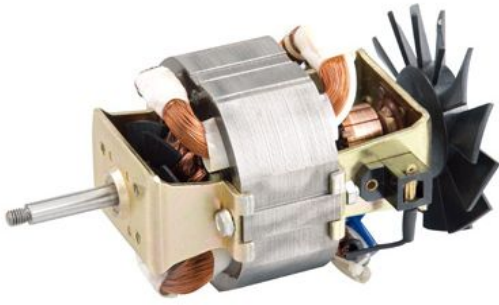

- Application—
- Juicer
- Milk Shaker
- Meat grinder
- Food Processor
- Blender
- Egg Beater and so on.

Mechanical Dimensions

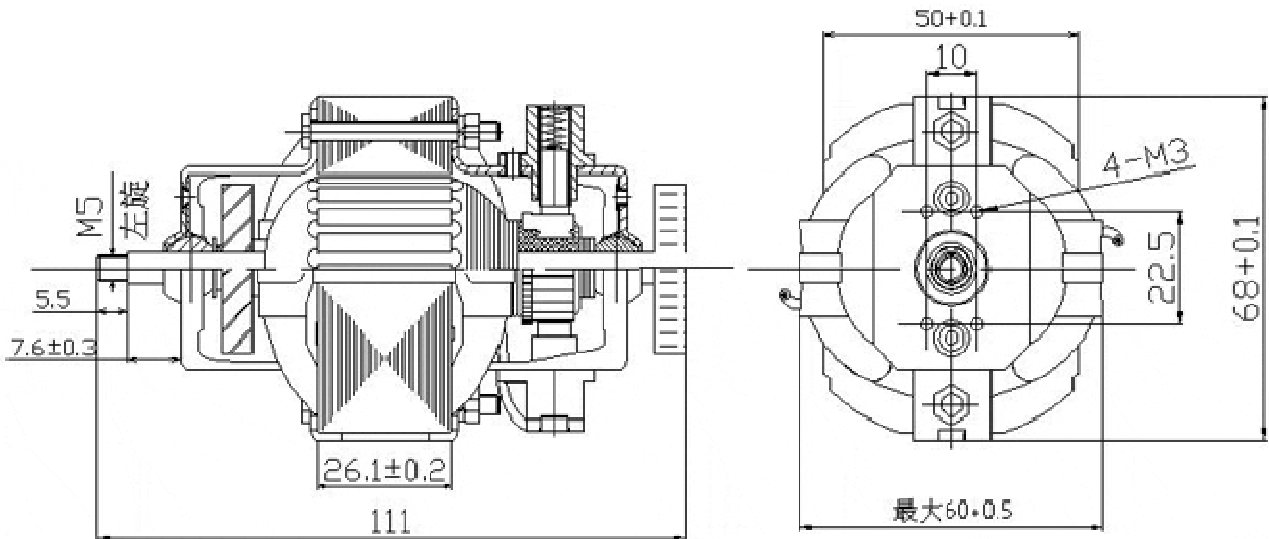

Technical Data

Model	Voltage (V)	Frequency (Hz)	No-Load			On-Load			Input power (W)	Output power (W)	Eff (%)
			Speed (RPM)	Current (A)	Power (W)	Speed (RPM)	Torque (N.m)	Current (A)			
UC68-26	220	50/60	20000	0.35	80	6800	0.2	1.32	274	142	51.8
UC68-26	110	60	19800	0.7	79	6780	0.2	2.8	277	142.7	51.5

Remark: We can produce according to customers requirement.

UC68-30 Universal Motor

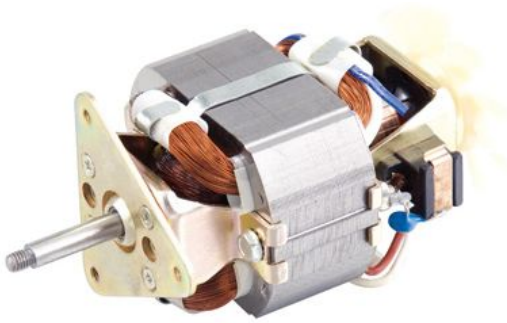

- Application—
- Juicer
- Coffee mill
- Soybean milk machine
- Food Processor
- Blender
- Egg Beater and so on.

Mechanical Dimensions

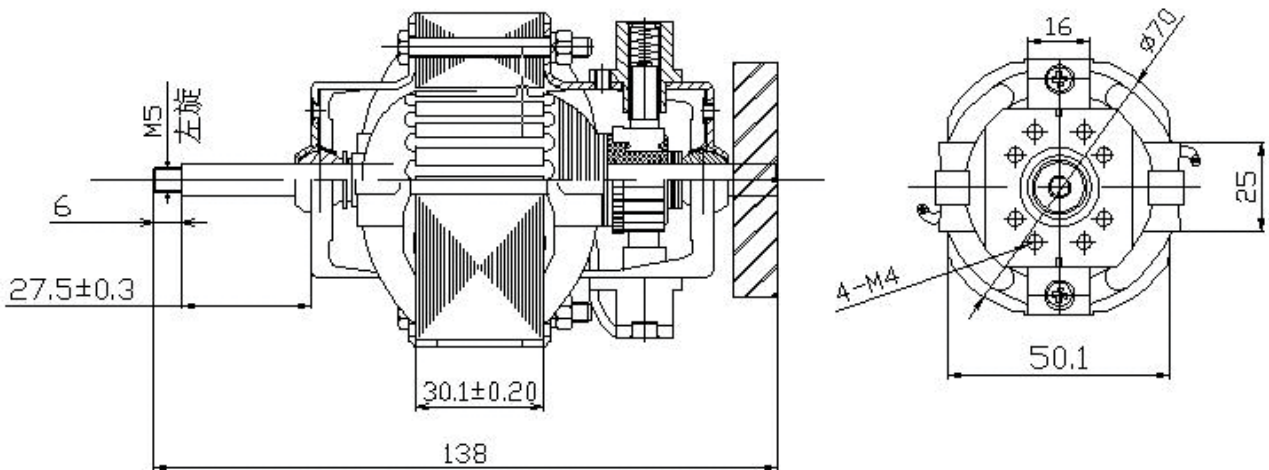

Technical Data

Model	Voltage (V)	Frequency (Hz)	No-Load			On-Load			Input power (W)	Output power (W)	Eff (%)
			Speed (RPM)	Current (A)	Power (W)	Speed (RPM)	Torque (N.m)	Current (A)			
UC68-30	220	50/60	19300	0.35	78	6720	0.2	1.215	256.2	135.4	52.8
UC68-30	110	60	19800	0.73	80	6650	0.2	2.75	280	138.6	49.4

Remark: We can produce according to customers requirement.

UC68-40 Universal Motor

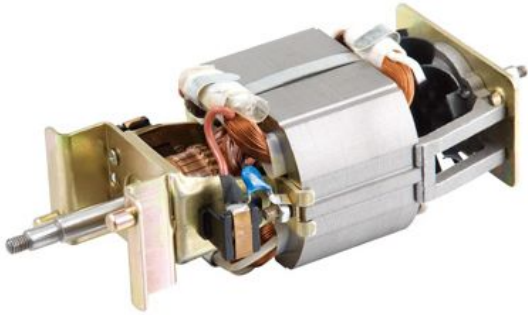

- Application—
- Juicer
- Coffee mill
- Soybean milk machine
- Food Processor
- Blender
- Egg Beater and so on.

Mechanical Dimensions

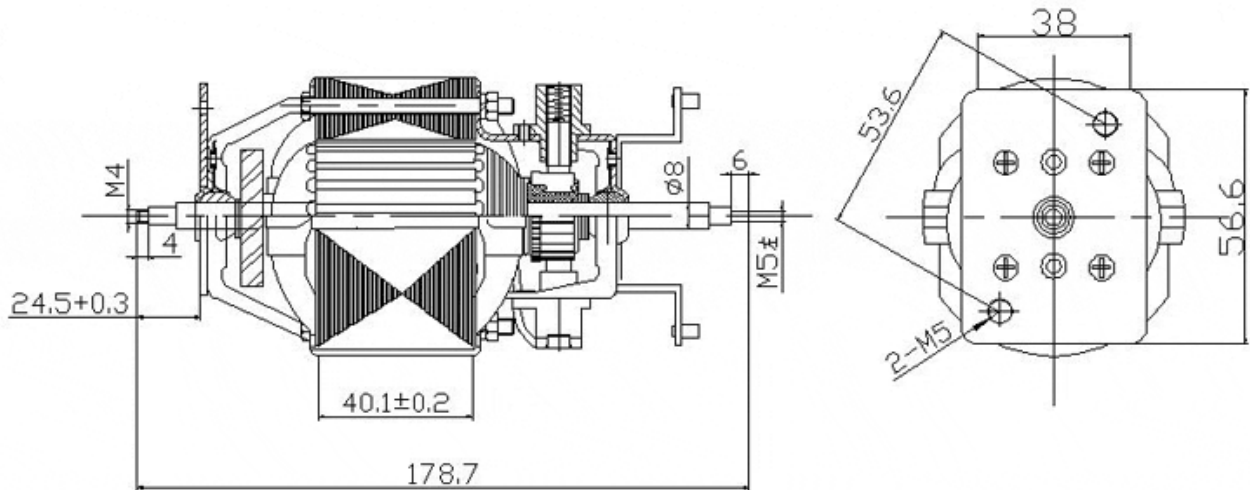

Technical Data

Model	Voltage (V)	Frequency (Hz)	No-Load			On-Load			Input power (W)	Output power (W)	Eff (%)
			Speed (RPM)	Current (A)	Power (W)	Speed (RPM)	Torque (N.m)	Current (A)			
UC68-40	220	50/60	17800	0.553	119	6675	0.230	1.715	329.6	167.4	50.7
UC68-40	110	60	18600	1.051	123.5	6560	0.230	3.42	325	162.5	50

Remark: We can produce according to customers requirement.

UC70-25 Universal Motor

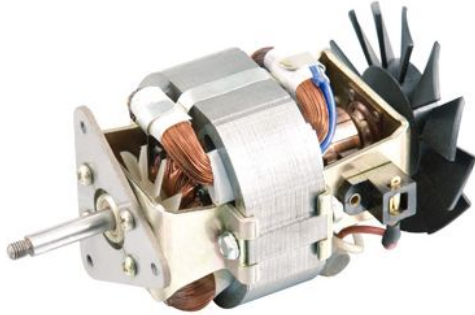

- Application—
- Juicer
- Bean grinder
- Soybean milk machine
- Food Processor
- Blender
- Coffee mill and so on.

Mechanical Dimensions

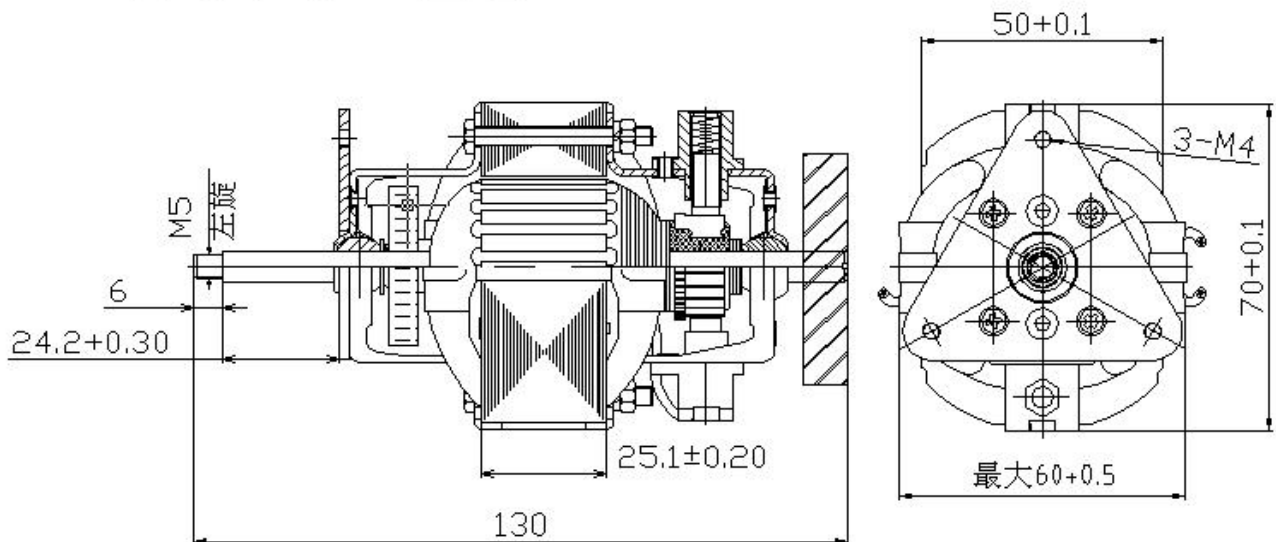

Technical Data

Model	Voltage (V)	Frequency (Hz)	No-Load			On-Load			Input power (W)	Output power (W)	Eff (%)
			Speed (RPM)	Current (A)	Power (W)	Speed (RPM)	Torque (N.m)	Current (A)			
UC70-25	220	50/60	18500	0.475	103	5802	0.181	1.463	300	129.9	43.3

Remark: We can produce according to customers requirement.

UC70-30 Universal Motor

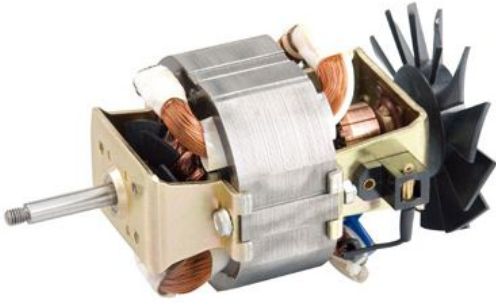

- Application—
- Juicer
- Soybean milk machine
- Bean grinder
- Food Processor
- Blender
- Coffee mill and so on.

Mechanical Dimensions

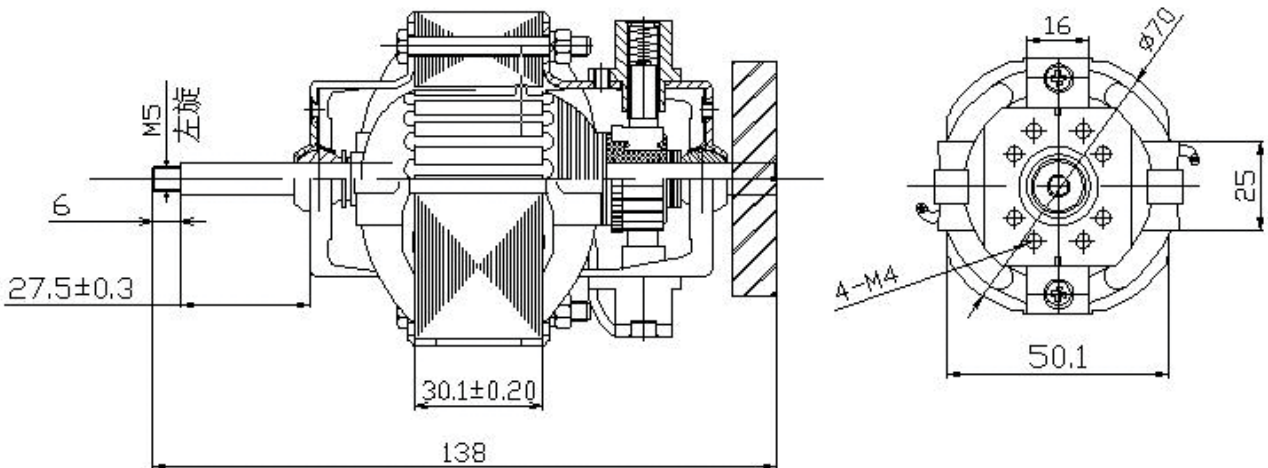

Technical Data

Model	Voltage (V)	Frequency (Hz)	No-Load			On-Load			Input power (W)	Output power (W)	Eff (%)
			Speed (RPM)	Current (A)	Power (W)	Speed (RPM)	Torque (N.m)	Current (A)			
UC70-30	220	50/60	16500	0.56	121.8	5207	0.202	1.492	301	136.1	45.2

Remark: We can produce according to customers requirement.

UC88-30 Universal Motor

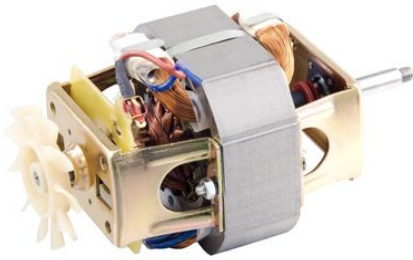

- Application—
- Meat grinder
- Soybean milk machine
- Food Processor
- Blender
- Noodle maker and so on.

Mechanical Dimensions

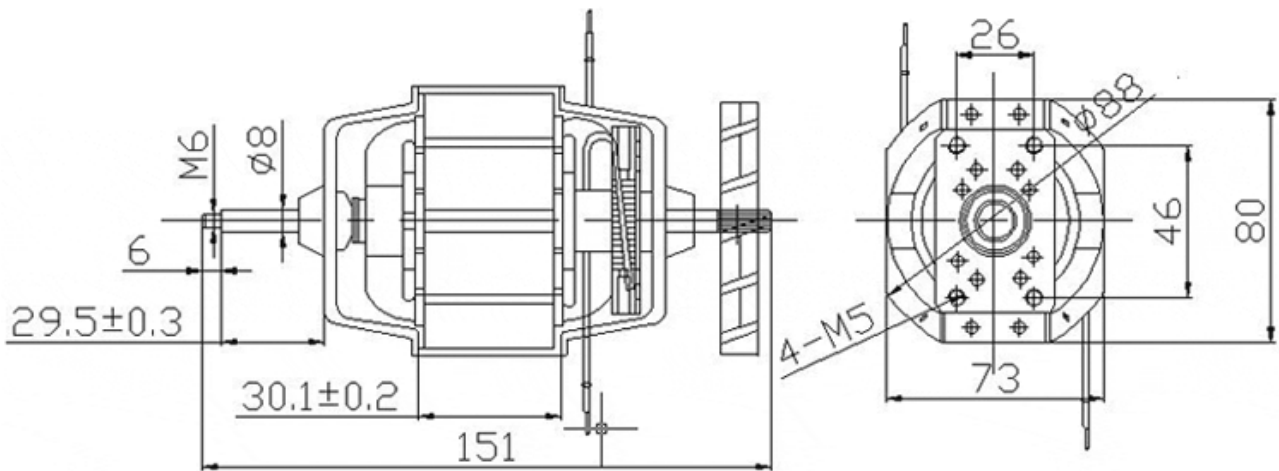

Technical Data

Model	Voltage (V)	Frequency (Hz)	No-Load			On-Load			Input power (W)	Output power (W)	Eff (%)
			Speed (RPM)	Current (A)	Power (W)	Speed (RPM)	Torque (N.m)	Current (A)			
UC88-30	220	50/60	18200	0.572	125	7365	0.299	2.207	456	230.6	50.5

Remark: We can produce according to customers requirement.

UC88-35 Universal Motor

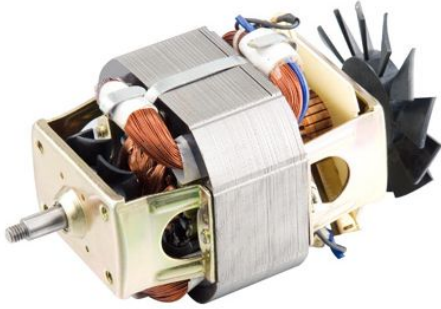

- Application—
- Meat grinder
- Soybean milk machine
- Food Processor
- Blender
- Noodle maker and so on.

Mechanical Dimensions

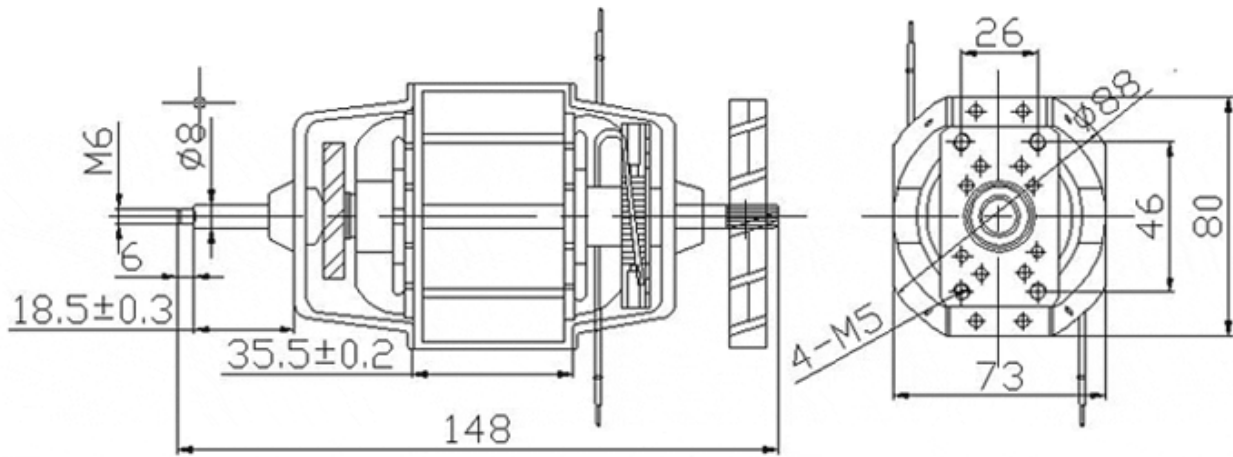

Technical Data

Model	Voltage (V)	Frequency (Hz)	No-Load			On-Load			Input power (W)	Output power (W)	Eff (%)
			Speed (RPM)	Current (A)	Power (W)	Speed (RPM)	Torque (N.m)	Current (A)			
UC88-35	220	50/60	17600	0.826	179	6988	0.414	3.021	602	302.9	50.3

Remark: We can produce according to customers requirement.

UC94-30 Universal Motor

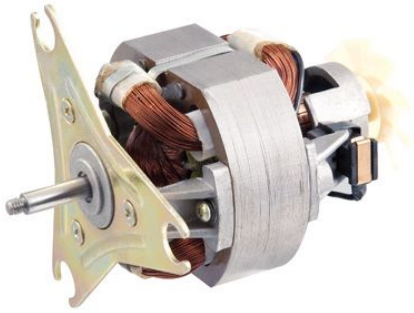

- Application—
- Juicer
- Blender
- Meat grinder
- Food Processor
- Bean grinder
- Soybean milk machine and so on.

Mechanical Dimensions

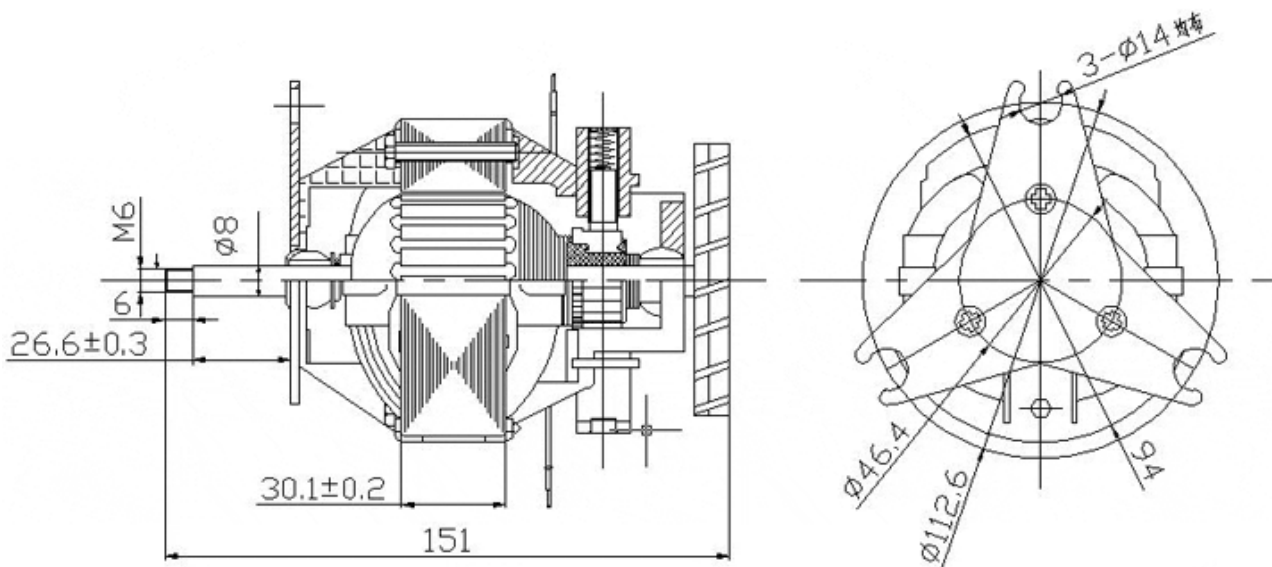

Technical Data

Model	Voltage (V)	Frequency (Hz)	No-Load			On-Load			Input power (W)	Output power (W)	Eff (%)
			Speed (RPM)	Current (A)	Power (W)	Speed (RPM)	Torque (N.m)	Current (A)			
UC94-30	220	50/60	17000	0.560	122	5800	0.315	1.75	356	187	52.5
UC94-30	127	60	17500	1.112	139	6661	0.366	4.46	501	255.3	50.9

Remark: We can produce according to customers requirement.

UC95-30 Universal Motor



- Typical Application—
- Ice machine
- and so on.

Technical Data

Model	Voltage (V)	Frequency (Hz)	No-Load			On-Load		
			Speed (RPM)	Current (A)	Power (W)	Speed (RPM)	Current (A)	Power (W)
UC95-30	220	50/60	24000	1.6	350	9200	4.6	1200

Remark: We can produce according to customers requirement.